

HONEYWELL
PART NUMBER
192-303KET-A01

REV	DOCUMENT	CHANGED BY	CHECK
C	0039479	SS 05MAY08	BLR

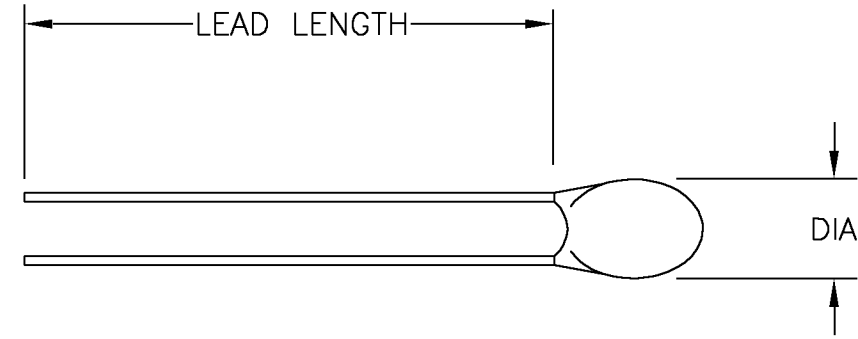

- CHIP 091-303KET-001
- DIAMETER .095 MAX
- LEAD LENGTH 1 1/2 MIN
- LEAD 900-032U1A-BBP WIRE
32 AWG TIN COATED COPPER ALLOY 180
- SOLDER 900-740S17-A01
TIN 96% SILVER 4%
- FLUX ORGANIC, WATER SOLUBLE
- COATING 908-5EPMIX-A60 (BLACK EPOXY)
- AGE 5 DAYS AT 105°C, 5 DAYS AT 50°C

RESISTANCE	TEMP. (°C)	MINIMUM (OHMS)	NOMINAL (OHMS)	MAXIMUM (OHMS)	REF. TOL.
	70	5312.9	5349	5385.4	±0.2°C
	0	94,545	95,490	96,445	±0.2°C

NOTE:
1. RoHS COMPLIANT

DESIGN UNITS: INCH	DRAWN	JES	02MAR99	Honeywell							
TOLERANCES UNLESS NOTED:	CHECK	WS	02MAR99								
FRACTIONS X ± 1/64	THIS DRAWING COVERS A PROPRIETARY ITEM AND IS THE PROPERTY OF HONEYWELL. THIS DRAWING IS NOT TO BE COPIED OR USED WITHOUT THE PERMISSION OF HONEYWELL.			TITLE			THERMISTOR OUTLINE				
ONE PLACE .X ± -				INTERPRET PER ASME Y14.5M-1994 OTHER HONEYWELL ENGINEERING STANDARDS MAY APPLY			SIZE	TYPE	DRAWING NAME	REV	
TWO PLACE .XX ± 0.01							B	I	192-303KET-A01	C	
THREE PLACE .XXX ± 0.005							SCALE		SHEET		1 OF 1
FOUR PLACE .XXXX ± -							AUTO CAD 2D				
ANGLES X ± 0°30'											

